

MariFlex MSP-100

Hydraulic driven portable pump

MariFlex development, manufacturing, sales, rental and repair of off-loading equipment/systems.

As a specialist in service and repairs, MariFlex has a very comprehensive selection of pumps, powerpacks and other equipment available for sale or rent, specially designed and purpose-built for the transshipment of liquid cargoes.

MariFlex can offer you equipment ranging from complete standard portable pumping installations to custom made turn-key marine equipment.

Upon request, MariFlex designs and builds special pumps, powerpacks and other equipment, according to internationally recognised standards and guidelines.



MariFlex MSP-100

The MariFlex MSP-100, a light and compact high capacity hydraulic driven centrifugal screw pump. Slow liquids speeds and low shear forces in the cargo are a direct consequence of the shape of the impeller, this makes the pump suitable for liquids which have to be handled carefully and without excessive motion and turbulence. This special quality of the pump makes it perfect for oil recovery operations.

The MariFlex MSP-100 is standard equipped with 0,5 mtr. self closing quick couplings with a locking device to prevent the couplings from separating accidentally. For safe connection to a ship's hydraulic system or a MariFlex portable power pack.

Suitable for operation in hazardous areas.
Low Emulsifying properties due to low velocities and low shear forces.
Non clogging characteristic. No overload risk when pump is blocked.

APPLICATIONS

Shipping - Industry - Oil recovery - Tank cleaning - Salvage - Sewage pumping.



MariFlex

MariFlex MSP-100

Hydraulic driven portable pump

Specifications: MariFlex MSP-100

Design	: Single stage centrifugal.
Capacity / head	: 150 m ³ /hr - 25 mwc max.
Viscosity / specific gravity	: 1.0 Cst. at 20 degr. / 1.0.
Speed	: 3380 rpm maximum.
Req. power consump.	: 20 Kw Maximum.
Materials casing	: Seawater resistant alum.
impeller	: Nodular cast iron / Stainless 316L.
Hydraulic motor	: Built on axial plunger. Hydromatik A2F-16
Hydraulic pressure	: 250 bar maximum.
Hydraulic oil flow	: 49 l/min. maximum.
Discharge connection	: 4 inch-100 mm with adaptor to 4 inch quick coupling.
Max. outer diameter	: 305 mm., fits through 12,5 inch std Butterworth hatch.
Height	: 430 mm.
Weight excluding hoses	: 28 Kgs.

Several Coast guards and oil recovery companies around the world use this type of pump as the standard for oil recovery operations.

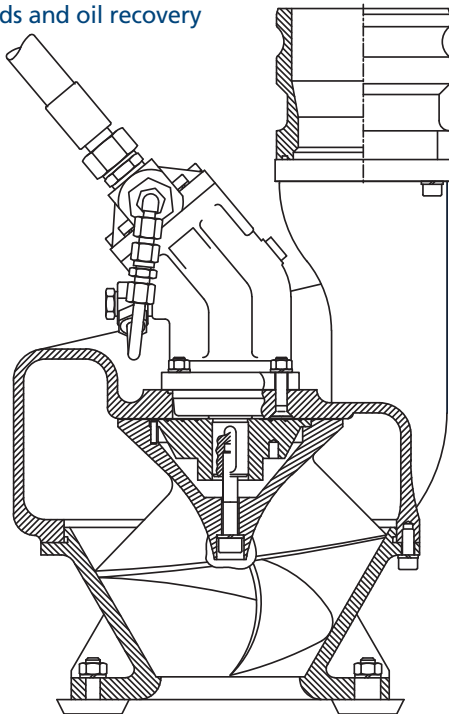

Test results MariFlex MSP-100

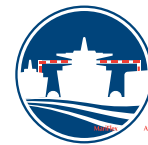
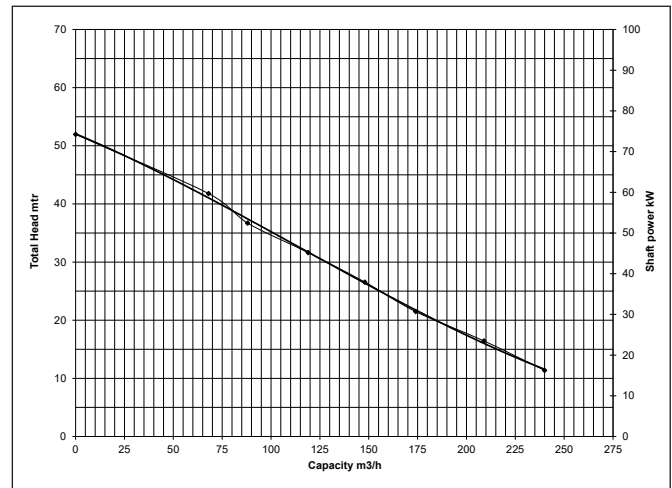

MariFlex Group

Maassluisdijk 101 | 3133 KA Vlaardingen
 Harbour no.: 738 | The Netherlands
 Phone +31 10 - 434 44 45 | info@mariflex.net
 www.mariflex.net



MariFlex